

R-2000iA™ Series

Basic Description

The R-2000iA series is FANUC Robotics' latest-generation, six-axis, heavy-payload, high-performance family of industrial robots, supported by our extensive service and parts network. The R-2000iA provides higher value through improved performance, reliability and maintainability. It features the SYSTEM R-J3iB intelligent robot control system.

R-2000iA, the Solution for:

- Automotive spot welding and general assembly
- General industrial applications
- Part transfer
- Material removal
- Dispensing
- Machine loading
- Arc welding

Benefits

- Slim arm and wrist assemblies minimize interference with system peripherals and allow operation in confined spaces.
- Large allowable wrist moments and inertias meet a variety of heavy handling challenges.
- Many process attachment points make integration easier.
- Stationary outer arm simplifies hose and cable dressout, prolonging service life.
- Proven, reliable FANUC servo drives provide highest uptime and productivity.
- Longer maintenance intervals equate to lower operating costs.
- Fewer mechanical components reduce down time, increase mean time between failure (MTBF) and minimize spare part requirements.
- High-performance motion yields fast cycle times and high throughput.
- Wrist flange and base mounting are identical to the S-430i, allowing for seamless backward compatibility.



- R-2000iA/165F can reach all areas of S-430i/W/165 work envelope, making replacement easy.

Features

Mechanical:

- Large work envelope with ability to reach overhead and behind
- 6 axes of motion
- Slim profile design
- RV reducers for all axes
- Elimination of counterweight increases available workspace
- Process/application cables routed through the arm
- No motors at wrist

Control:

- B-size cabinet
- Quick change amplifier <5 min.
- Fast boot time <30 sec.
- Standard Ethernet port
- PCMCIA Software distribution
- Easy connections to a variety of I/O, including a number of distributed I/O networks
- iPendant, a color, Internet-ready teach pendant for even easier programming and custom cell user interface design

Software:

- Process specific software packages for various applications
- Web-based software tools for remote connectivity, diagnostics and production monitoring
- Machine vision for robot guidance and inspection

Options

- Enhanced severe dust and liquid protection package with two-part epoxy paint for harsh environments.
- Standard baseplate for quick robot installation.
- Auxiliary axes packages for integration of peripheral servo-controlled devices.
- Adjustable hard stops for J1, J2 and J3.
- Various robot connection cable lengths for flexible cabinet placement and optional track rated cables.
- iPendant is also available with touch screen support.
- Monochrome pendant available.
- Integrated spot welding utilities.
- Electrically insulated faceplate.

FANUC
Robotics

R-2000iA/165F, 210F

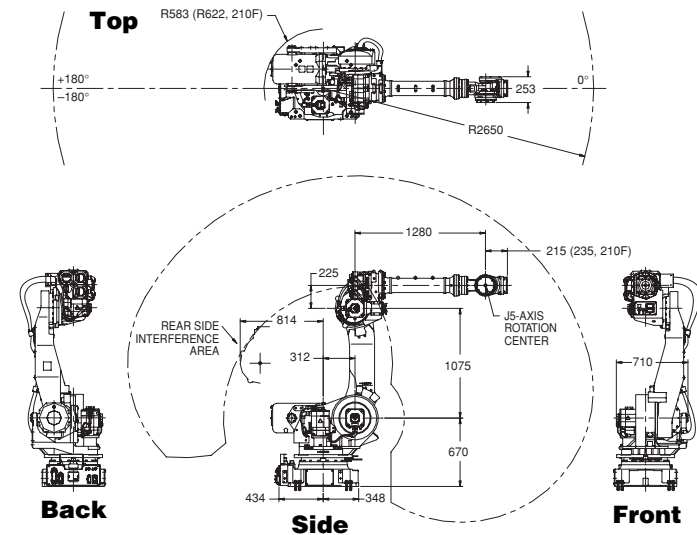

ISO Flange Wrist 165F, 165R, 125L

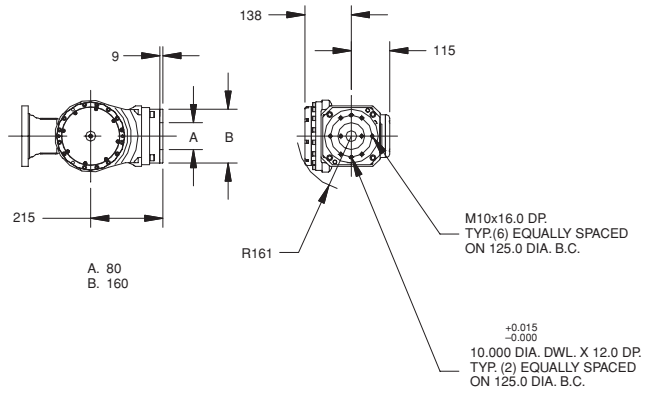

R-2000iA/200FO

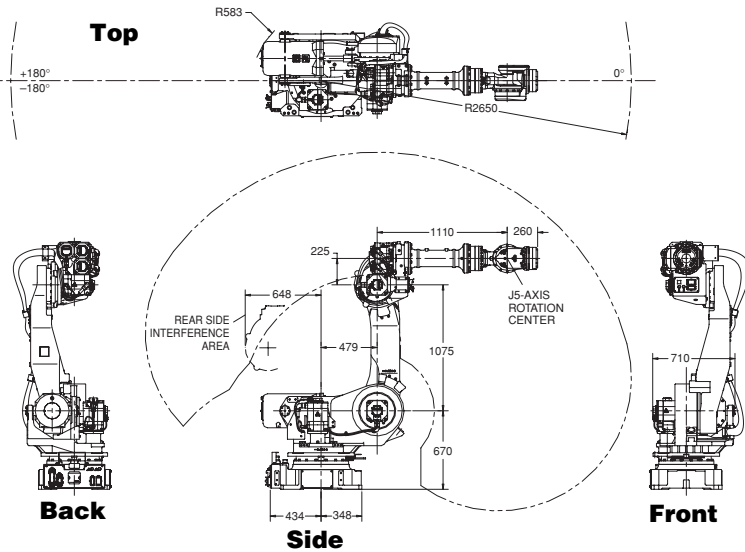

ISO Flange Wrist 200R, 200FO, 130U

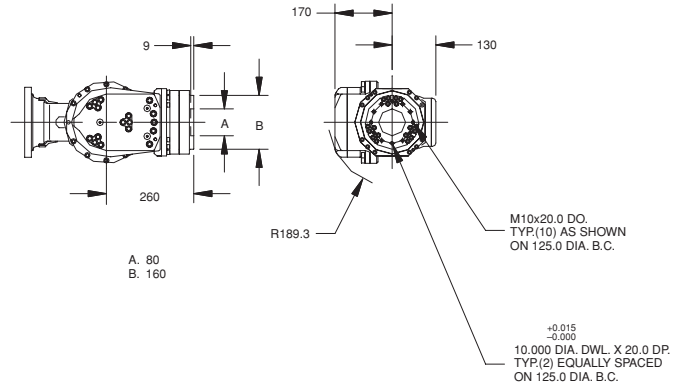

R-2000iA/125L

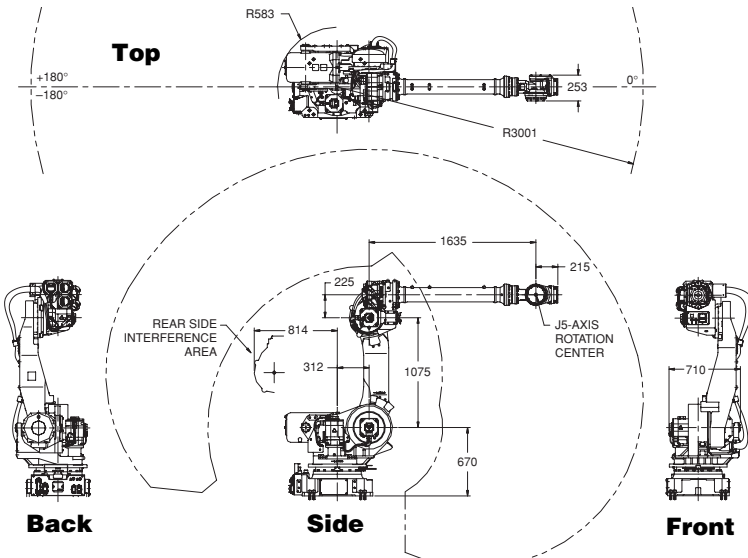

ISO Flange Wrist 210F, 100P

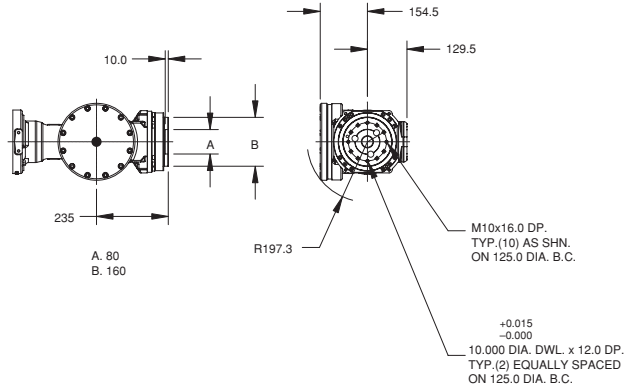

R-2000iA/165R

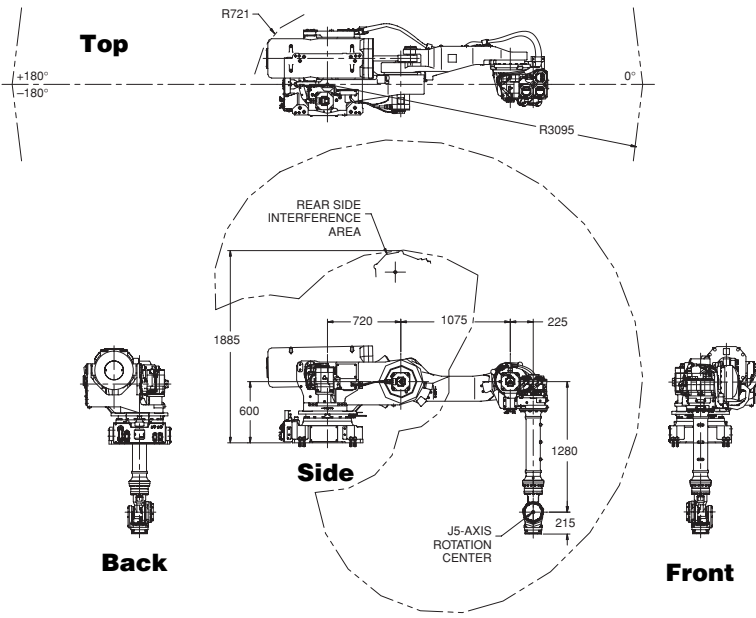

R-2000iA/130U

NOTE: ROBOT CAN PASS IN THE HATCHED AREA, BUT CANNOT REST IN THIS AREA.

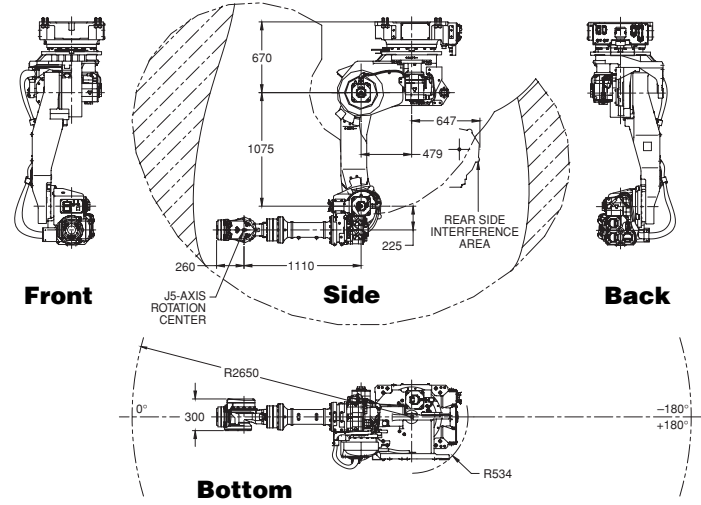

R-2000iA/200R

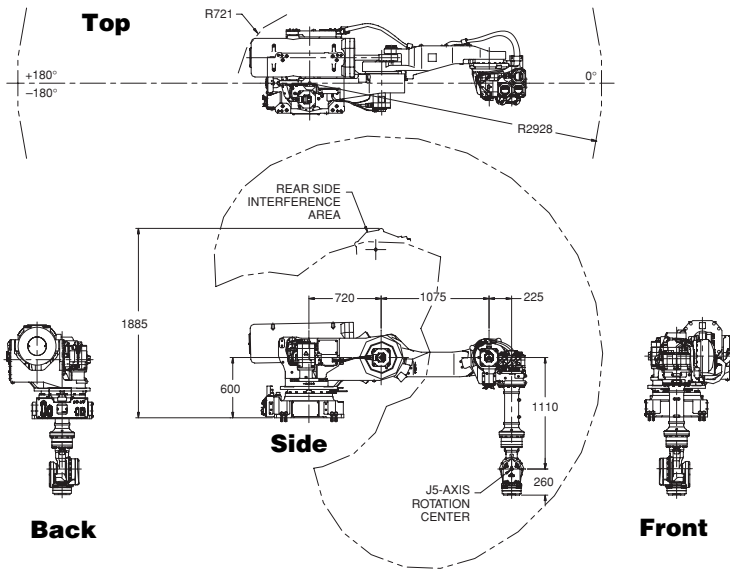

Isometric 165F

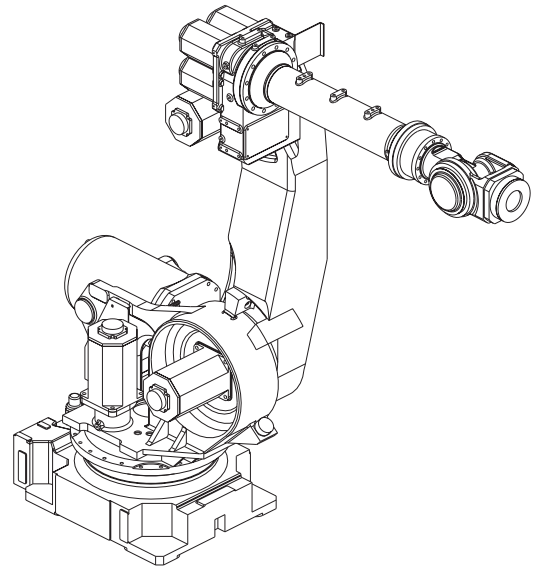

R-2000iA/100P

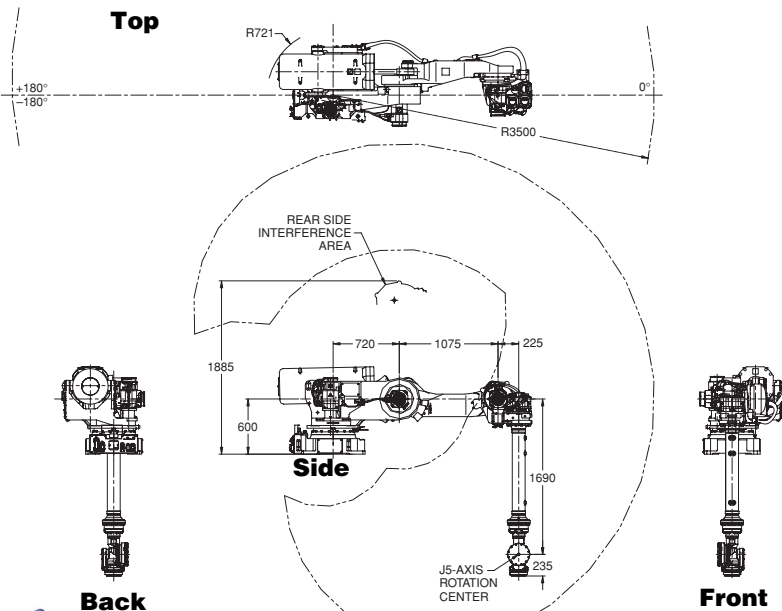

Footprint (All models)

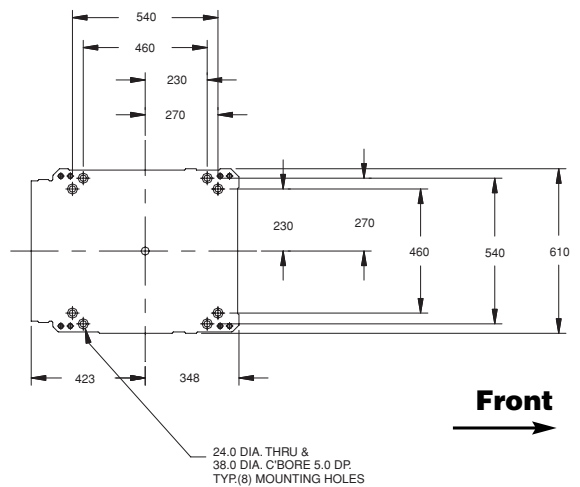

Note: Dimensions are shown in millimeters. Detailed CAD data are available upon request.

R-2000iA Specifications

Items	/165F	/210F	/200FO	/125L	/165R	/200R	/100P	/130U
Axes	6	6	6	6	6	6	6	6
Payload - Wrist (kg)	165	210	200	125	165	200	100	130
- J3 Arm (kg)	25	25	25	20	25	0	25	25
- J2 Base (kg)	550	550	550	550	550	550	550	550
Reach (mm)	2650	2650	2650	3001	3095	2928	3500	2650
Repeatability (mm)	± 0.3	± 0.3	± 0.3	± 0.3	± 0.3	± 0.3	± 0.3	± 0.3
Repeatability under constant motion speed (mm)	± 0.18	--	--	± 0.18	--	--	--	--
Interference radius	583	622	583	583	721	721	721	534
Motion range (degrees)	J1	360	360	360	360	360	360	360
	J2	135	135	135	135	185	185	135
	J3	362	361	350.4	352	365	365	367.5
	J4	720	720	720	720	720	720	720
	J5	250	250	250	250	250	250	250
	J6	720	720	720	720	720	720	720
Motion speed (degrees/s)	J1	105	95	90	105	105	90	105
	J2	105	90	85	105	90	85	90
	J3	105	95	90	105	105	90	105
	J4	130	120	110	170	130	110	120
	J5	130	120	110	170	130	110	120
	J6	210	190	155	260	210	155	190
Wrist moment (kgf·m)	J4	94	136	130	60	94	100	70
	J5	94	136	130	60	94	100	70
	J6	47	72	70	35	47	72	35
Wrist inertia ¹ (kgf·cm·s ²)	J4	800	1440/2200	1200/2200	600	800	2300	417
	J5	800	1440/2200	1200/2200	600	800	2300	417
	J6	410	800/2000	600/2000	230	410	2000	104
Mechanical brakes	All axes	All axes	All axes	All axes	All axes	All axes	All axes	All axes
Mechanical weight (kg)	1210	1270	1310	1230	1540	1570	1630	1210
Mounting method	Floor	Floor	Floor	Floor	Shelf	Shelf	Shelf	Ceiling
Installation environment	0 to 45 Normally: 75% or less Short term (within a month): 95% or less No condensation (No dew or frost allowed)							
Ambient temperature °C								
Humidity								
Vibration (m/s ²)								
IP rating(s) ²	Wrist & J3 arm IP67, rest IP54 (IP66 drivetrain optional)							
Purpose	Floor mount	Heavy duty floor mount	Floor mount - forward option	Long arm floor mount	Shelf mount	Heavy duty shelf mount	Shelf mount - press robot	Ceiling mount - forward option

Notes:

- (1) Allowable load inertia at wrist can be switched by software parameters.
- (2) IP66 drivetrain option is not available on R-2000iA/100P.



FANUC Robotics America, Inc.
3900 W. Hamlin Road
Rochester Hills, MI 48309-3253
(248) 377-7000
Fax (248) 377-7362

Charlotte, NC
(704) 596-5121

Chicago, IL
(847) 898-6000

Toronto, Canada
(905) 812-2300

Montréal, Canada
(450) 492-9001

For sales or technical information, call:
1-800-47-ROBOT

Cincinnati, OH
(513) 754-2400

Aguascalientes, Mexico
52 (449) 922-8000

Los Angeles, CA
(949) 595-2700

Sao Paulo, Brazil
(55) (11) 3619-0599

marketing@fanucrobotics.com
www.fanucrobotics.com

Toledo, OH
(419) 866-0788

